

Caddx Farsight

Quick Start Guide

V1.0

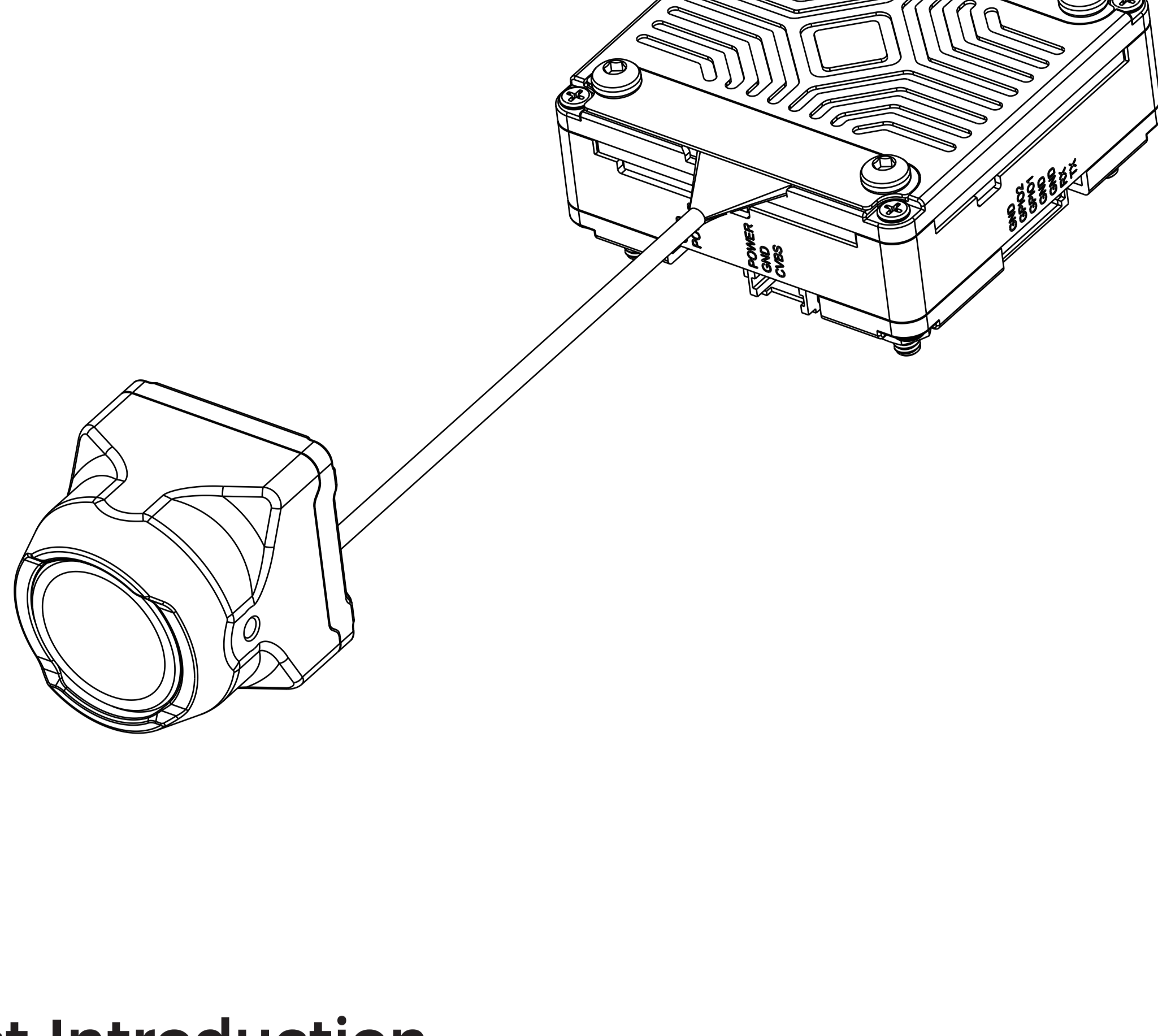

Product Introduction

The main features of the Caddx Farsight are as follows:

● Fast Zoom:

The Farsight 8x zoom camera features fast zoom capability. During the zooming process, it is quick and smooth, without the need to wait for the focus and zooming process as with traditional zoom lenses. It adopts a hybrid zoom solution combining optical, digital, and AI algorithms.

● Lightweight Design:

With an ultra-compact size of just 19mm x 19mm, there is no need to carry the large size and volume of optical zoom lenses. Supports analog output functionality. Supports remote control for zoom operations on the camera.

Installation Direction

*During installation, please ensure this side is facing upwards to prevent the image from being upside down.

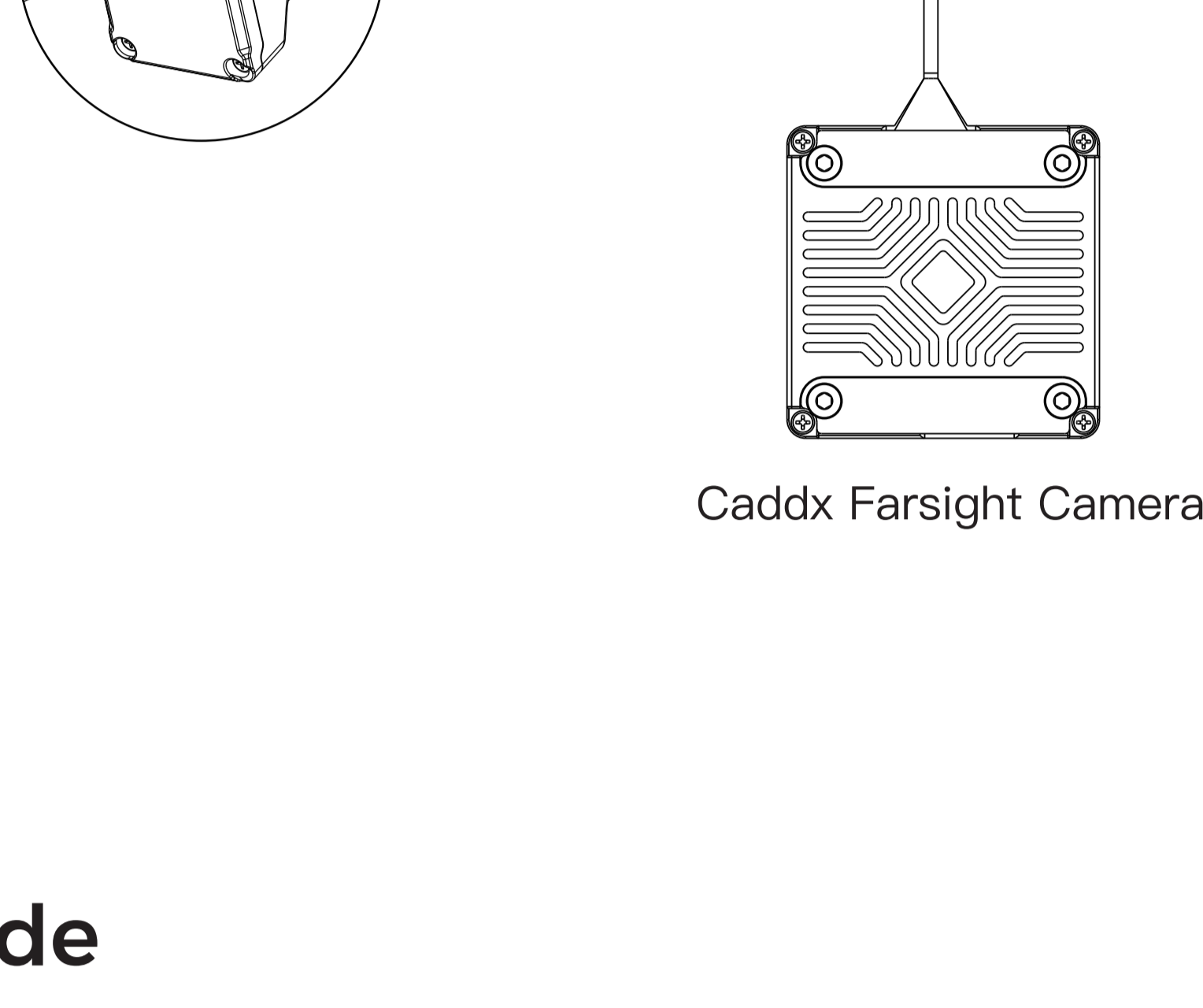

Control Mode

Zoom Function Control: The zoom operation is controlled via PWM signals output by the flight controller. For example, when the PWM signal duty cycle is 100%, the image is displayed at 1x magnification; when the duty cycle is 200%, the image is magnified 2x.

Reset Function Control: To ensure a quick switch from high magnification to 1x zoom, an IO-defined switch is used for reset operations. For example, if the current zoom magnification is 8x, triggering the reset switch will restore the image to 1x magnification. When the IO switch is turned off, the zoom will return to the previous magnification level.

*** Recommended Button Settings:**

- The zoom function is controlled via a rotary switch.
- The reset function is controlled via a two-position toggle switch.

Connection

Power / CVBS Connection:

- POWER: FC pad 9~24V
- GND: Connect to the GND
- CVBS: Connect to the FC CAM interface

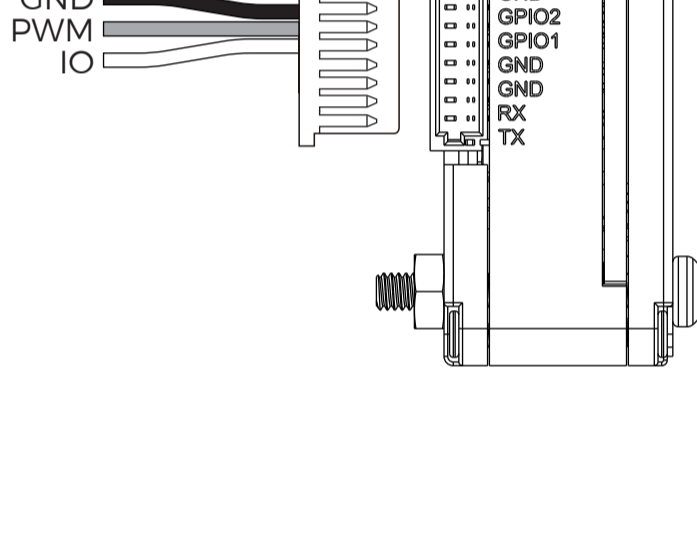

Control Line Connection:

- GND: Connect to the GND
- GPIO2: Input PWM signal for zoom control
- GPIO1: Input IO signal for reset definition

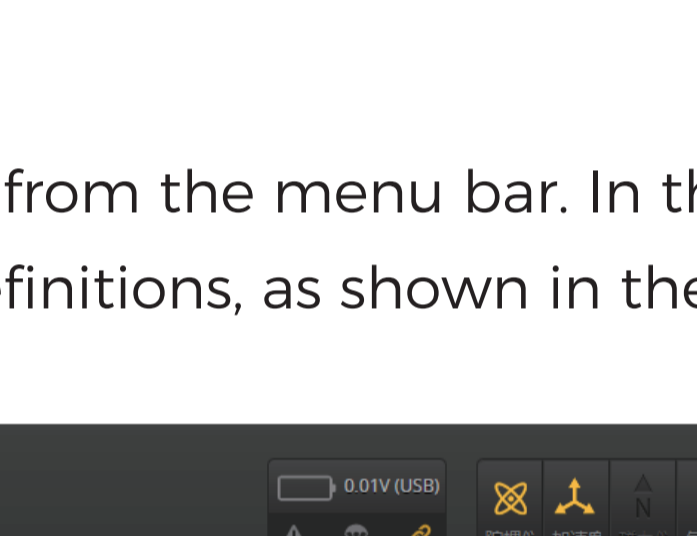

Debugging Procedure

Example Hardware Connection:

- GPIO1: Connect to flight controller TX1
- GPIO2: Connect to flight controller M6

In the Betaflight program, select the "CLI" option from the menu bar. In the text box, enter the command "resource" to load and view the pin definitions, as shown in the image below:

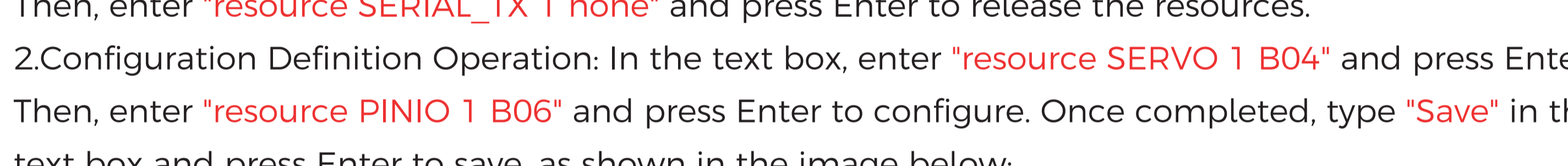

- Release Occupation Operation: In the text box, enter "resource MOTOR 6 none" and press Enter. Then, enter "resource SERIAL_TX 1 none" and press Enter to release the resources.
- Resource Definition Operation: In the text box, enter "resource SERVO 1 B04" and press Enter. Then, enter "resource PINIO 1 B06" and press Enter to configure. Once completed, type "Save" in the text box and press Enter to save, as shown in the image below:



RC Channel Configuration:

- In the Betaflight program, select the "Modes" option from the menu bar. Find "USER1" and click to debug. When channel 8 is set to a two-position toggle switch, select the "AUX 8" channel. Click the save button, as shown in the image below:

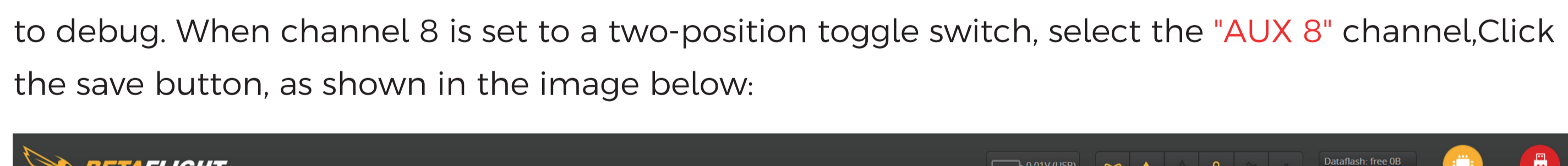

- In the Betaflight program, select the "Configuration" option from the menu bar. In the "Other Features" section, check the box to enable "SERVO_TILT". Click the Save and Restart button, as shown in the image below:



- In the Betaflight program, select the "Servos" option from the menu bar. If the remote control channel A4 is set to a rotary switch, check the box for "Servo 1" and enable the "A4" remote control channel to complete the setup. Click the save button, as shown in the image below:



Specifications

Name	Caddx Farsight
Model	MN13-0014B
Image Sensor	1/2 inch
Illuminance	0.01Lux
Focal Length	2.2mm
FOV	122.5°(H) x 92.2°(V) x 155°(D)
Horizontal Resolution	1500TVL
Aspect Ratio	4:3
Zoom Ratio	1-8X
Zoom Mode	Connect to FC, PWM Control
Power Interface	CVBS
Power Supply Range	9~24V
Power Consumption	<2w
Operating Temperature	-20 C ~60 C
Dimensions	Camera: 19x19x19.5mm AI Box: 33.5x33.5x12.35mm

CADDXFPV Support
Email: support@caddxfpv.com

Caddx Farsight

使用说明

V1.0

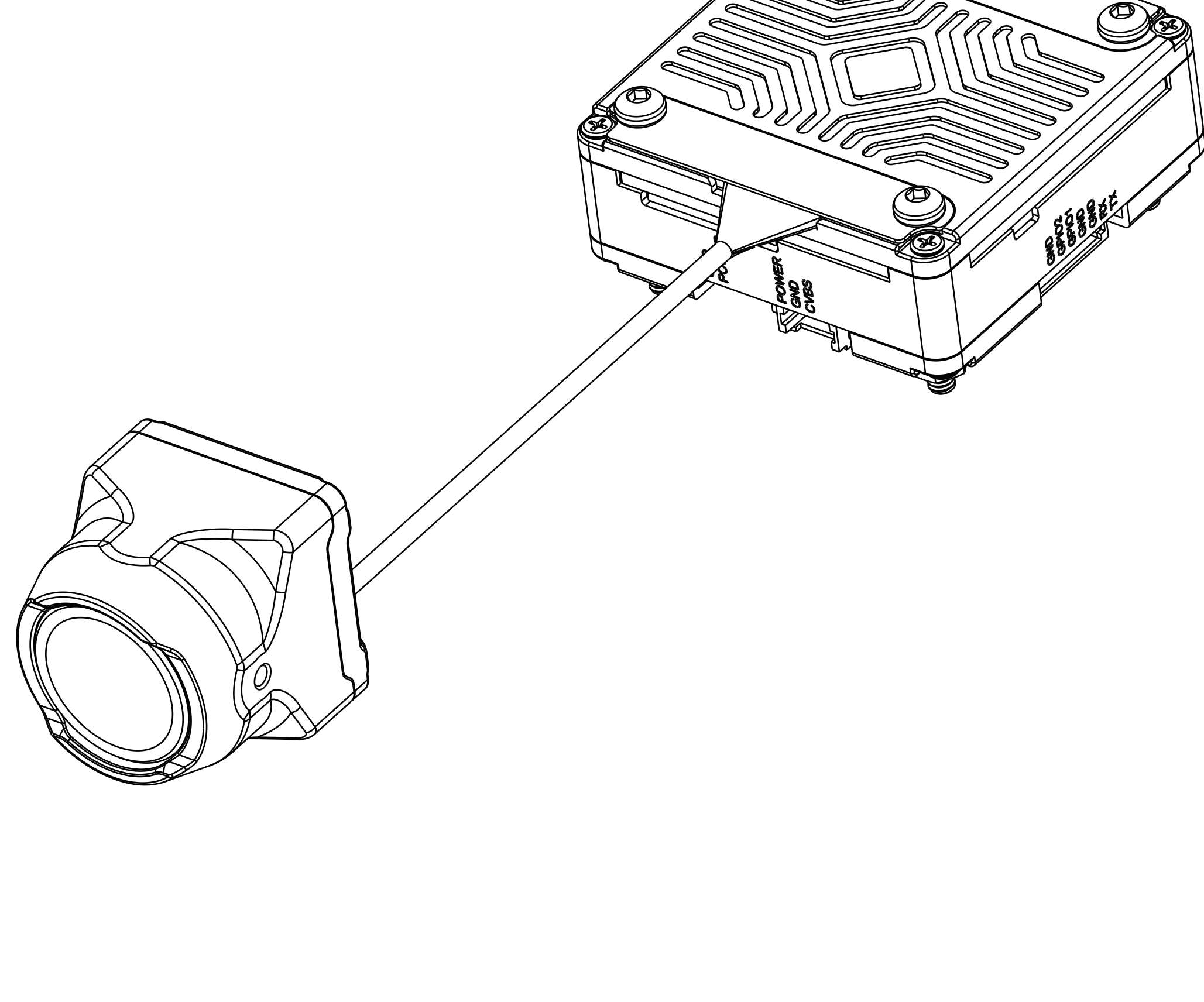

产品简介

Caddx Farsight主要特征如下:

● 快速变倍:

Farsight 8倍变焦相机具备快速变倍能力。在变倍过程中，它迅速且流畅，无需像传统变倍镜头有等待变焦、对焦的过程；

采用光学、数字、AI算法混合的变倍方案。

● 小巧轻盈:

超小体积，仅为19mmx19mm。无需承受光学变倍镜头的庞大体积和尺寸；

支持模拟输出功能；

支持遥控器对相机进行变倍操作。

安装朝向

*安装时请根据此画面朝向上，以免图像画面颠倒

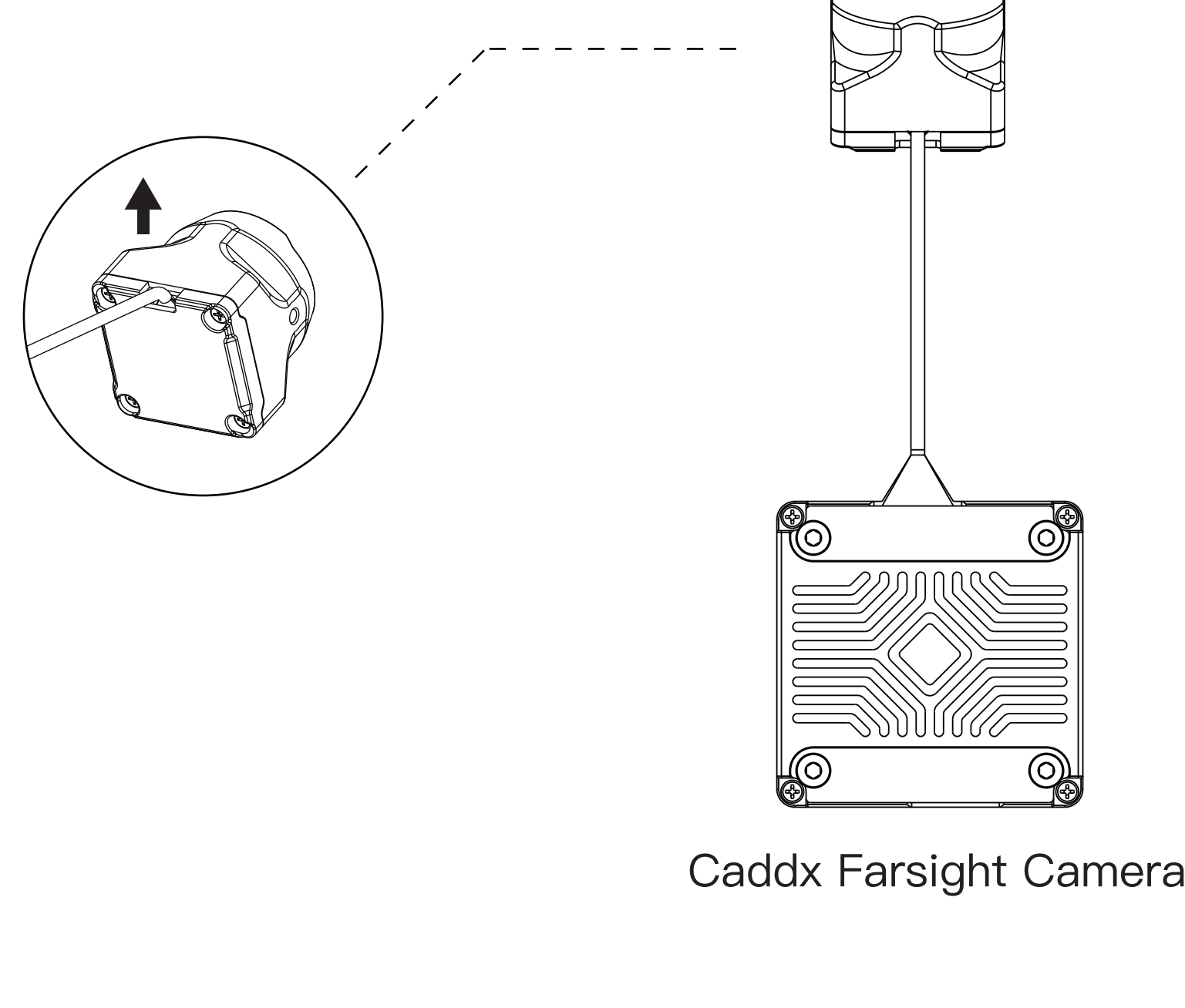

Caddx Farsight Camera

控制方式

变焦功能控制：使用飞控输出PWM信号实现变焦操作。举例来说，当PWM信号占空比为100时，图像效果为1倍放大；当PWM信号占空比为200时，图像效果为2倍放大。

复位功能控制：为了确保可以从高倍率快速切换至1倍放大，通过IO定义一个开关进行复位操作。例如，如果当前变焦倍率为8倍，触发复位开关后将恢复至1倍放大状态。关闭IO开关后将恢复至之前的变焦倍率状态。

* 建议按键设定：变倍功能通过旋钮开关控制

复位功能通过二段拨杆控制

接线方式

- 1.POWER: 飞控焊盘9~24V
- 2.GND: 接负极线(GND)
- 3.CVBS接入飞控CAM接口

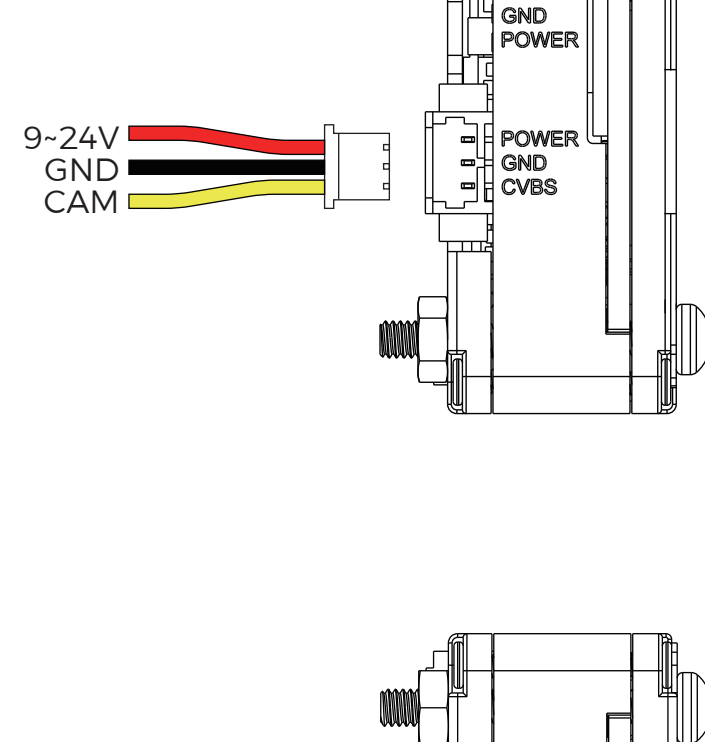

- 1.GND: 接负极线
- 2.GPIO2: 输入PWM信号用于控制变倍
- 3.GPIO1: 输入IO信号用于定义复位

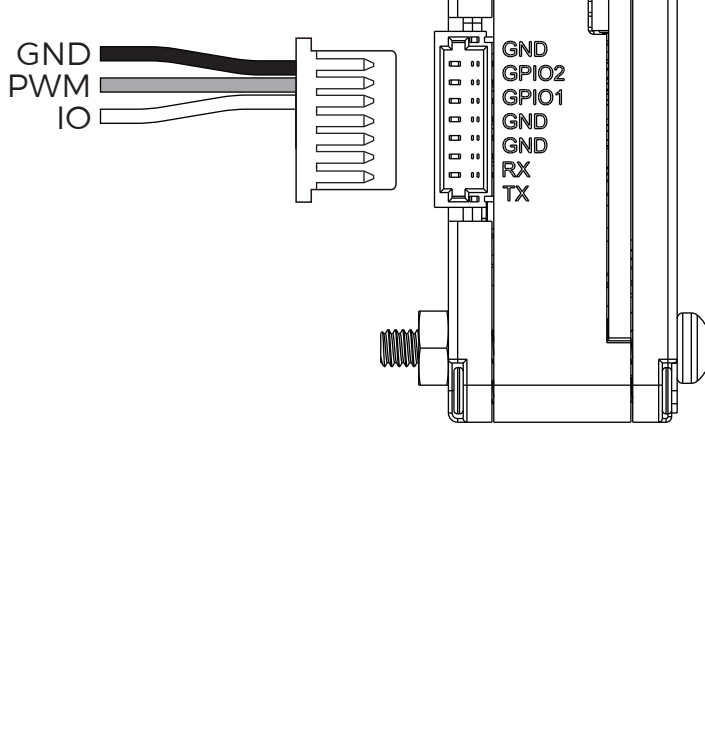

调式步骤

示例硬件接线：GPIO1接入飞控TX1

GPIO2接入的飞控M6

在Betaflight程序中菜单栏选择“CLI”选项，在文本框输入命令“resource”加载查看引脚定义，如下图所示：

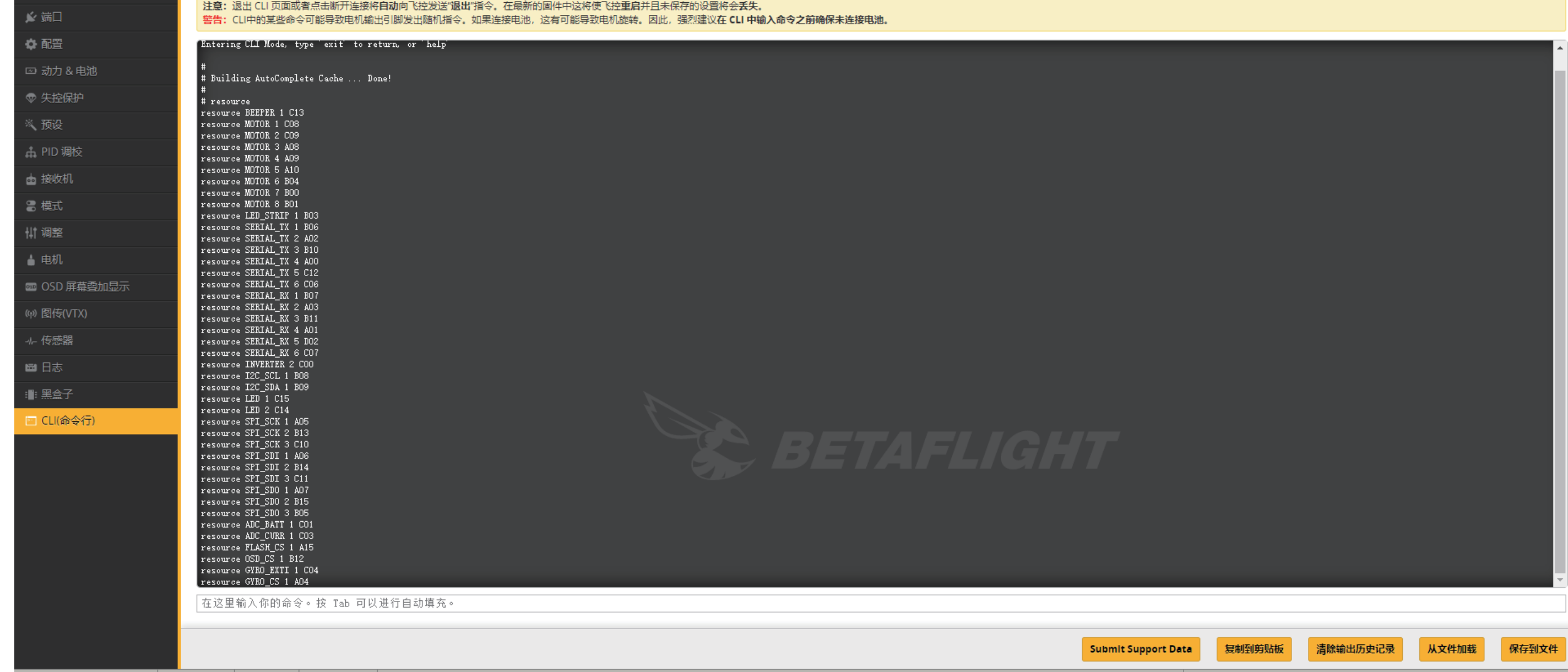

- 1.解除占用操作：文本框输入“resource MOTOR 6 none”回车；再输入“resource SERIAL_TX 1 none”回车进行解除；
- 2.配置定义操作：文本框输入“resource SERVO 1 B04”回车；再输入“resource PINIO 1 B06”回车进行配置，完成后在文本框输入“Save”回车即可保存，如下图所示：



遥控器通道设置：

- 1.在Betaflight程序中菜单栏选择“模式”选项，找到“USER1”点击进行调试，当前通道8为二段拨杆时，则选择“AUX 8”通道，点击保存按钮，如下图片所示：



- 2.然后在Betaflight程序中菜单栏选择“配置”选项，在“其他功能”界面中将“SERVO_TILT”勾选打开，点击保存并重启按钮，如下图所示：

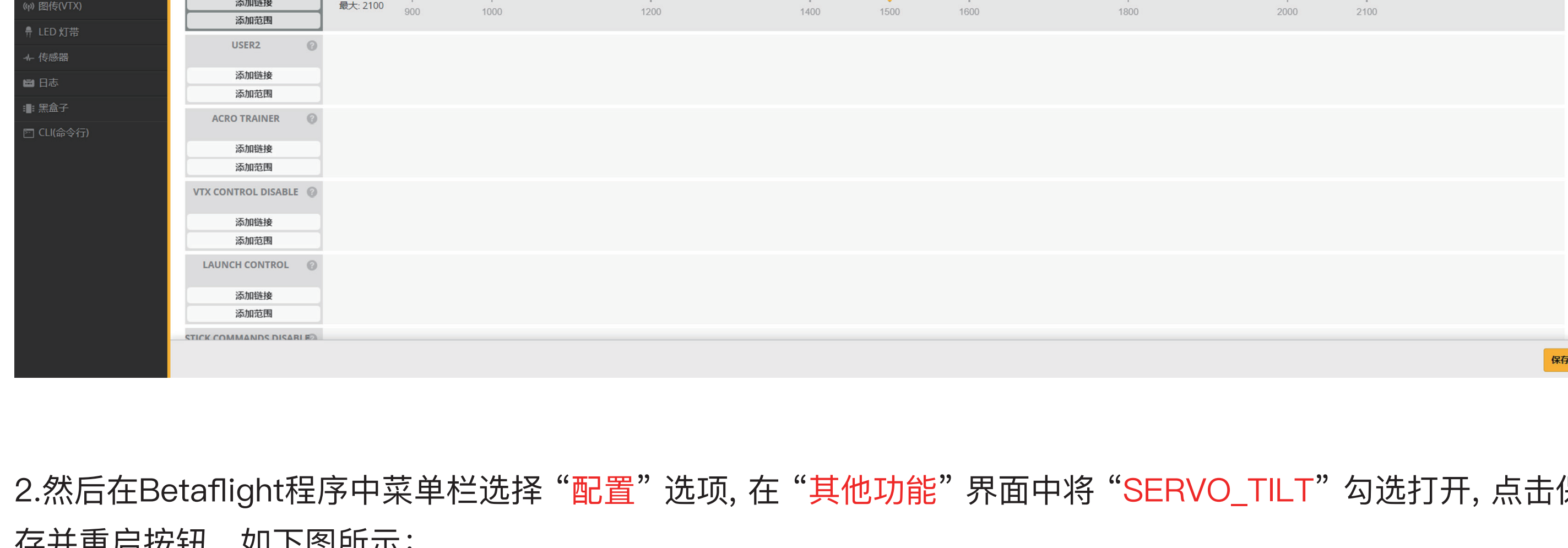

- 3.最后在Betaflight程序中菜单栏选择“舵机”选项，如当前遥控器A4为旋钮开关时，可在“Servo 1”勾选打开“A4”遥控器通道即完成，点击保存按钮，如下图所示：

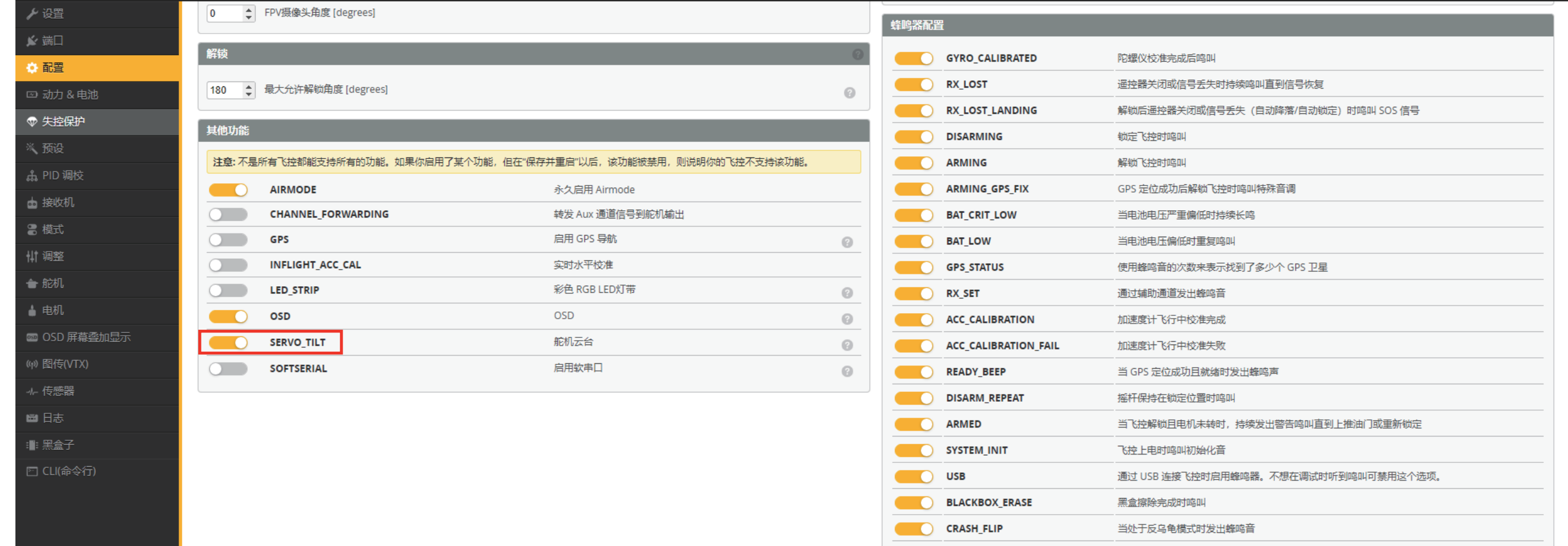

产品规格

名称	Caddx Farsight
型号	MN13-0014B
图像传感器	1/2 inch
光照度	0.01Lux
焦距	2.2mm
FOV	122.5°(H) x 92.2°(V) x 155°(D)
水平分辨率	1500TVL
画面比例	4:3
变倍倍率	1-8X
变倍方式	连接飞控，PWM控制
视频接口	CVBS
供电范围	9~24V
功耗	<2W
工作温度	-20°C~60°C
尺寸	Camera: 19x19x19.5mm AI Box: 33.5x33.5x12.35mm